

Using the KODAK EKTACOLOR Processing Cartridge 92/110,

CAT No. 144 0775, for KODAK EKTACOLOR EDGE, ROYAL Digital, and KODAK PROFESSIONAL PRO IMAGE and PROFOTO Color Papers



The KODAK EKTACOLOR Processing Cartridge 92/110, Catalog No. 144 0775 is a drop-in cartridge of paper processing chemicals that will process 110 square metres (1184square feet) of KODAK EKTACOLOR EDGE, ROYAL Digital, KODAK PROFESSIONAL PRO IMAGE and PROFOTO Color Papers.

The EKTACOLOR Processing Cartridge 92/110, CAT No. 144 0775, replaces KODAK EKTACOLOR Processing Cartridge 75, CAT No. 528 5887.

This cartridge is designed for use in KODAK PROFESSIONAL RP 30 and SRP 30 Printers, and also in AGFA d-lab.2 Printers, using KODAK EKTACOLOR EDGE, ROYAL Digital, and KODAK PROFESSIONAL PRO IMAGE and PROFOTO Color Papers. The cartridge will produce prints with rich, bright colors and excellent shadow detail. It provides production efficiency that will satisfy even the highest-volume lab operations.

Note: The KODAK EKTACOLOR Processing Cartridge 92/110 can also process 92 square metres (990 square feet) of KODAK PROFESSIONAL PORTRA ENDURA, SUPRA ENDURA, ULTRA ENDURA, and ENDURA Metallic Color Papers. For information on using the KODAK EKTACOLOR Processing Cartridge 92/110 for KODAK Professional Color Papers, see Publication CIS-239, *Using the KODAK EKTACOLOR Processing Cartridge 92/110, CAT, No. 144 0775, for Professional Color Papers, in KODAK PROFESSIONAL RP 30 and SRP 30 Printers.*

The EKTACOLOR Processing Cartridge 92/110 will be offered worldwide. It will be available in the U.S. and Europe in spring 2007, and worldwide during the summer 2007.

CARTRIDGE DESCRIPTION

Each cartridge case holds two processing cartridges. Each cartridge contains concentrates to make 4.5 litres (1.2 gal) of developer replenisher, 7.5 litres (2 gal) of bleach-fix replenisher, and 4.5 litres (1.2 gal) of stabilizer replenisher to process 92 square metres (990 sq ft) of paper.

The KODAK PROFESSIONAL RP 30, SRP 30, and AGFA d-lab.2 Printers will prepare the replenisher solutions directly in the replenisher storage tanks of the printer/paper processor, and will automatically signal when a replacement cartridge is needed.

CONVERTING TO KODAK EKTACOLOR PROCESSING CARTRIDGE 92/110

Converting to the new KODAK EKTACOLOR Processing Cartridge 92/110, CAT No. 144 0775, is simple.

For AGFA d-lab.2 Printers, no adjustments to software are usually needed. Simply load the new cartridge and start processing. You can check your replenishment rates to make sure they are correct using the procedure below.

Do not use the older KODAK EKTACOLOR Processing Cartridge 75, CAT No. 528 5887, in AGFA d-lab.2 Printers.

For KODAK PROFESSIONAL RP 30 and SRP 30 Printers, adjustments to software may be needed. Check, and if necessary, adjust the replenishment rates using the procedure listed below. Then simply load the new cartridge and start processing.

Rates for 110 m² (for d-lab.2)

To check Paper Processor replenishment rates:

- Touch: Settings
- Machine settings
- PP Replenishm.

The screen should look as follows:

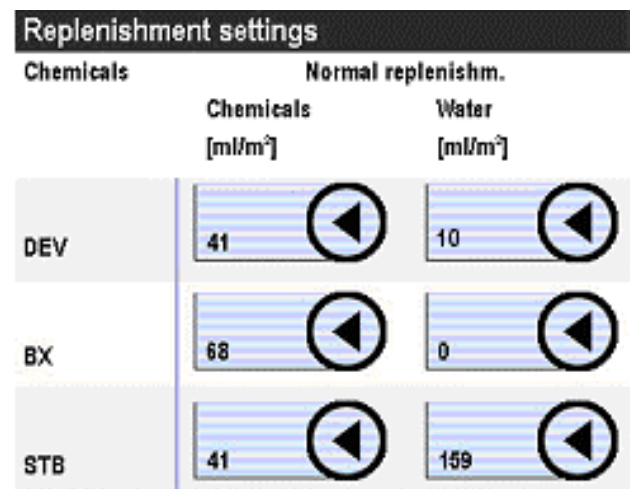

To set new Paper Processor replenishment rates:

- Touch the first button next to **DEV** and enter **41**. (BX and STB will automatically change.)

- Touch the second button to the right of **DEV** (**DEV Water**) and enter **10**.
- Touch the second button to the right of **STB** (**STB Water**) and enter **159**.
- Touch **OK** to save the new values.

Note for AGFA d-lab.2 Printers: During a loading/mixing cycle, the bleach-fix replenisher may foam due to introduction of air. To prevent this from occurring, see the modification in APPENDIX A.

PROCESSING STEPS AND CONDITIONS

The steps and conditions of the process cycle in the KODAK PROFESSIONAL RP 30, SRP30, and AGFA d-lab.2 Printers are given in Table 1.

Table 1 Processing Steps and Conditions

Solution/Step	Time* (sec)	Temperature	Replenishment Rate† mL/m ²
Developer	33	40.0 ± 0.3°C 104.0 ± 0.5°F	41 replenisher 10 water
Bleach-Fix	33	38 ± 3°C 100 ± 5°F	68 replenisher
Stabilizer	69‡	37 ± 3°C 99 ± 5°F	41 replenisher 159 water
Dry		Not over 70°C (158°F)	—

*Immersion time plus crossover time to the next tank.

†The replenishment rates are starting-point recommendations.

‡Four stabilizer tanks plumbed for countercurrent flow.

Note: All solutions and tanks are automatically circulated and filtered.

Replenishment Rates

The rates in Table 1 are starting-point recommendations. Your replenishment rates will also depend on these factors:

- type of paper processed
- exposure level of the paper and resulting print density
- other variables of the processing system, such as production volume

If you change any one of the three replenishment rates in the Chemicals column, the other two will automatically be changed so that all replenisher chemistry will run out at the same time. We recommend that changes be made only to the developer rate. Changes can be made to any one of the three water rates without changing the other two.

Developer. If necessary, adjust the replenishment rate according to your control plots (see "Using Control Strips to Monitor the Process").

Bleach-Fix. The bleach-fix replenishment rate assumes minimum carryover of developer. If developer carryover is greater than normal, problems such as retained silver may occur. If you detect retained silver, verify that the replenishment rate is set correctly and that the processor rollers are adjusted to minimize developer carryover. See the printer manual for specifications and adjustments for squeegee rollers.

Filtration

Processing solutions and wash water may contain some insoluble materials. If these materials aren't filtered out, they can stick to the paper, tank walls, rollers, and lines, and may damage the paper. Change the filters regularly as a part of routine maintenance.

Drying

The maximum drying temperature setting in the software of KODAK PROFESSIONAL RP 30/SRP 30 and AGFA d-lab.2 Laser Printers is 70°C (158°F).

Low Utilization

The number of prints that you produce each week determines the utilization of the printer processor. If your utilization is low, oxidation and evaporation will affect the activity of the processing solutions and may increase the D-min of the paper.

During periods of low utilization, be sure to turn off the processor when it's not in use to avoid oxidation and evaporation. In extreme cases of low utilization, you may need to discard the chemicals in the processor and replace them with fresh tank solutions.

SAFE HANDLING OF PHOTOGRAPHIC CHEMICALS

Handle all chemicals carefully. When you mix solutions, wear goggles or a face shield, a protective rubber apron, and protective gloves made with neoprene or nitrile rubber. Clean protective clothing after use to remove any chemical residue that can cause contamination. For more information about potential health hazards and safe handling of specific Kodak chemicals, see the label and the Material Safety Data Sheet (MSDS) for the chemical. Consult the MSDS for regional contact information. Kodak will provide Material Safety Data Sheets (MSDSs) with the first delivery of the KODAK EKTACOLOR Processing Cartridge 92/110, Catalog No. 144 0775. MSDSs will also be available on the Kodak website at www.Kodak.com/go/photochemicals.

Also, for use in the United States, OSHA Warning Labels for the printer processor tanks are available at www.Kodak.com/go/KES. These warning labels for chemical working tank solutions will assist you in complying with the OSHA Hazard Communication Standard. When combined with the use of Material Safety Data Sheets, they'll help ensure that users are informed about chemicals in the workplace.

PREPARING FRESH TANK SOLUTIONS

Follow these instructions to prepare developer, bleach-fix, and stabilizer working tank solutions for the KODAK PROFESSIONAL RP 30, SRP 30, and AGFA d-lab.2 Printers from the concentrate solutions in the KODAK EKTACOLOR Processing Cartridge 92/110.

Preliminary Steps

- Before removing bottles from the cartridge, identify the concentrate bottles needed by looking at the cartridge diagram on the front label of the PC 92/110 cartridge. Note the order of each different concentrate bottle, and what each is. Note also that the CD and BX-B have the same size bottle, but can be identified by the order in the box and by the fill volume noted in the diagram. The diagram on the label will appear as follows:

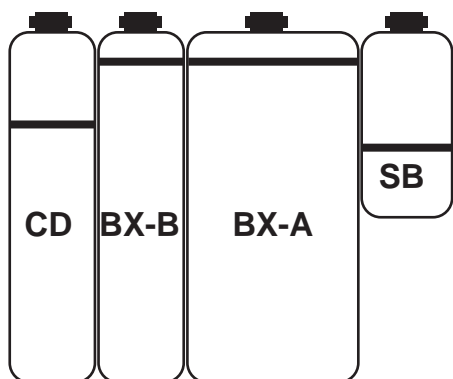

You will need two bottles of each part to prepare the working tank solutions.

- To prepare the developer tank solution, you will also need KODAK EKTACOLOR RA Developer Starter. CAT numbers for different regions are as follows:

Region	CAT No.
US&C, Latin America (Northern)	102 6681
Europe, Africa, Middle East	527 8957
Latin America (Southern)	632 0238
Greater Asia Region	444 5839 403 6596

- Assemble the following equipment for accurate measurement of the concentrates and water:
 - graduated cylinder that can measure volumes up to 1 litre
 - container to measure volumes of water up to 10 litres
- Remove the racks from the processor tanks and rinse the tanks with water. **Be sure to close the drain valves again before adding the fresh solutions to the tanks.**

Mixing the Tank Solutions

Mix the working tank solutions for the stabilizer, bleach-fix, and developer as follows:

Stabilizer. Identify the two stabilizer concentrate bottles from the two EKTACOLOR Processing Cartridge 92/110 cartons. To mix solution for the four stabilizer tanks, you will need to split the volume of concentrate in each bottle in half.

Use the stabilizer concentrate to mix the working tank solution for **each** tank as follows:

For <u>Each</u> Stabilizer Tank	Volume
Add water to each stabilizer tank	10.9 litres
Add one-half bottle of stabilizer concentrate (labeled SB on diagram)	Approximately 87 mL
Total volume per tank	11 litres

Bleach-Fix. Identify the bleach-fix Part A and Part B concentrate bottles from the two EKTACOLOR Processing Cartridge 92/110 cartons. **Be very careful to avoid contamination of the developer with bleach-fix.**

For Bleach-Fix Tank	Volume
Add water to bleach-fix tank	12.4 litres
Add contents of two bottles of bleach-fix concentrate, Part A (labeled BX-A on diagram)	Entire contents of two bottles
Add contents of two bottles of bleach-fix concentrate, Part B (labeled BX-B on diagram)	Entire contents of two bottles
Total tank volume	18.4 litres

Developer. Follow the procedure below to prepare the developer working tank solution. To ensure good performance, take special care in mixing the developer.

For Developer Tank	Volume
Add water to developer tank	15.7 litres
Slowly add contents of two bottles of developer concentrate (labeled CD on diagram)	Entire contents of two bottles
EKTACOLOR RA Developer Starter	1100 mL
Total tank volume	18.4 litres

Reinstalling the Racks and Bringing the Tank Solutions to Temperature

When you fill the tanks with the new mixes, they will appear only partially filled. When you reinstall the racks in the tanks, the racks will displace more solution volume to fill the tanks.

Install the racks by slowly lowering them into the tank. When you have reinstalled all the racks and have verified that all the tanks are filled with solution, turn on the recirculation and heater system and bring the solutions up to operating temperature:

Solution Tank	Temperature °C
Developer	40.0 ± 0.3
Bleach-Fix	38 ± 3
Stabilizer	37 ± 3

Note: After mixing, rinse the concentrate bottles, and dispose of them in an approved manner. See “Managing Empty Cartridges.”

Maintaining Stabilizer Tank Solutions

All photographic processing equipment requires ongoing maintenance to ensure that wash tanks and stabilizer tanks remain clean and provide proper washing of photographic materials. This is true for traditional “plumbed” running-water wash systems as well as “non-plumbed” stabilizer wash systems commonly used in minilab processors. Without occasional tank and rack cleaning and replacement of the stabilizer, you may experience dirt and precipitate buildup in the tanks.

We recommend that you clean stabilizer tanks and racks and replace the stabilizer solution if you experience an increase in D-min—typically seen as yellow stain—or whenever you see excessive dirt on print surfaces.

The need for stabilizer tank maintenance will vary with factors such as water quality and the production volume of the processor. Most labs find that they need to change stabilizer at intervals ranging from once every few weeks to once every few months. Replacement of solution in the first tank or the first two tanks following the bleach-fix tank may be sufficient to resolve problems.

The following procedure for replacing the stabilizer tank solution recommends the use of KODAK EKTACOLOR PRIME Stabilizer and Replenisher LORR. When you use this stabilizer, you avoid having to use a portion of the chemicals in the KODAK EKTACOLOR Processing Cartridge 92/110.

Note: For all maintenance steps, observe the precautions given under “Safe Handling of Photographic Chemicals.”

To change the stabilizer:

1. Drain the existing tank solution and save it for silver recovery.
 2. Remove the racks and clean them thoroughly with a soft sponge or brush under running water. Also brush any dirt or residue from the sides of the stabilizer tanks, and flush them with warm water.
 3. To refill the tanks with fresh stabilizer, add 10.9 litres of water to each of the stabilizer tanks. If you are using stabilizer supplied in a dispenser bottle (European CAT 527 0863), then start with 10.8 litres of water.
 4. To each tank, add the contents of one bottle of the 10-litre size of KODAK EKTACOLOR PRIME Stabilizer and Replenisher LORR. If you’re using a stabilizer unit that makes a larger volume of solution, measure 100 mL of the concentrate and add it to each tank. The tank will appear partially filled.
If you are using dispenser bottle* CAT 527 0863, then add the quantity 2x the level A mark. The tank will appear partially filled.
- *Not available in all regions.
5. Slowly insert the stabilizer racks in each tank; the solution will mix and the tank will fill.

USING CONTROL STRIPS TO MONITOR THE PROCESS

You can use KODAK Control Strips, Process RA-4, Box of 50, CAT No. 828 2170, or Box of 25, CAT No. 898 2746, to monitor and help maintain process performance. For instructions on processing control strips, see the user’s manual for the printer. For information on the use and diagnostic features of the control strips, see KODAK Publication No. Z-130, *Using KODAK EKTACOLOR Chemicals, Section 7, “Process Monitoring and Troubleshooting,”* available from www.Kodak.com/go/photochemicals.

To calculate control-strip aim values for process monitoring with the EKTACOLOR Processing Cartridge 92/110, you will need to apply process adjustment factors. Use the adjustment factors in addition to the correction factors that are supplied with the KODAK Control Strips, Process RA-4.

After reading the densities of the supplied reference strip on your densitometer, first apply the correction factors for EKTACOLOR PRIME packaged with the reference strip. Then add the values from the following table. The corrected density values are the aim values for your batch of control strips. You will need to apply the adjustment factors each time you switch to a new batch of control strips.

Table 2 Process Adjustment Factors

Measurement	R	G	B
BP	+0.01	+0.03	+0.06
HD	+0.09	+0.12	+0.11
LD	+0.17	+0.23	+0.14
D-min	0	0	0

SILVER RECOVERY

The overflows from the developer and bleach-fix tanks are collected in a common tank on the KODAK PROFESSIONAL RP 30, SRP 30, and AGFA d-lab.2 Laser Printers. The stabilizer overflow is collected in a second tank. The two effluent tanks are connected at the top. If one is full, it will overflow into the other tank. Typically, silver concentrations in the developer/bleach-fix effluent tank will be 2 to 4 g/L of silver. The stabilizer effluent tank will have a typical silver concentration of 0.4 to 0.7 g/L.

You can effectively use common silver-recovery methods with the combined effluent from both effluent collection tanks. If your lab has other processors, you can combine the effluent from the RP 30, SRP 30, and AGFA d-lab.2 Printers with the other effluent solutions and use your current silver-recovery methods. Publications on silver management that include recommendations and descriptions of silver-recovery options are available in the Silver Management section of the Kodak Environmental Services Publications Center at www.Kodak.com/go/KES.

MANAGING EMPTY CARTRIDGES

In most regions, it should be possible to participate in a local community recycling program. Check with program authorities to determine if these packaging materials are eligible for local recycling. If they are accepted, disassemble the package and place the bottles and corrugated material in your recycling bin. Follow all material preparation instructions from the recycler.

See KODAK Publication No. CIS-148, *Recycling KODAK Photochemical Containers*, for more information on preparing the empty bottles for recycling. CIS-148 and other publications on waste management are available on the Kodak website at www.Kodak.com/go/KES.

If local recycling is not an option, dispose of the empty bottles and the package with your normal solid waste.

APPENDIX A:

Installation of KODAK Upgrade Kit, Bleach-Fix Replenishment Tank for AGFA d-lab.2 Printers

KODAK Upgrade Kit
Bleach-Fix Replenishment
Tank for AGFA d-lab.2
Printers

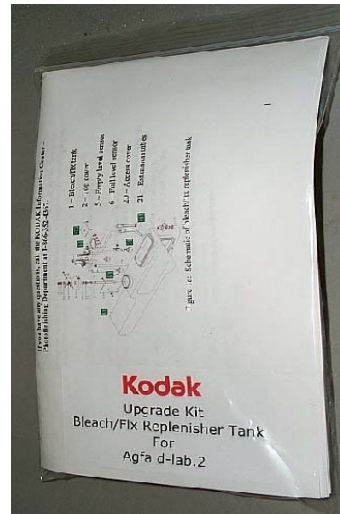
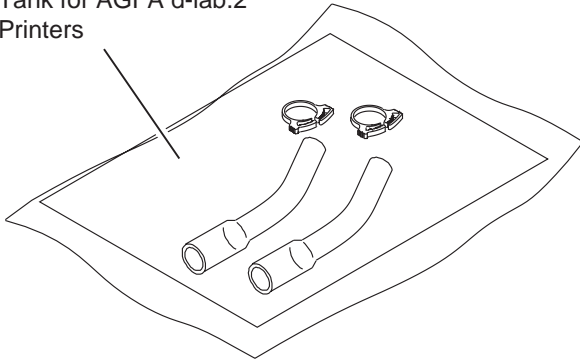

F005_0033ACA
F005_0033AC

The KODAK Upgrade Kit, Bleach-Fix Replenisher Tank, for AGFA d-lab.2 Printers, is an optional modification you can install to reduce potential for foaming of the bleach-fix replenisher during a mixing cycle. You can obtain these kits from your Kodak Account Manager, or by contacting the Kodak Information Center, Photofinishing Group, at 1-866-352-4367. In Europe you can obtain these kits by contacting your local Kodak Service & Support organization.

AGFA d-lab.2 Printers use stabilizer overflow and/or water to mix bleach-fix replenisher. These solutions are

introduced either directly into the top of the bleach-fix replenishment tank, or into the bottom of the tank by the use of extender hoses. All KODAK PROFESSIONAL RP 30 and SRP 30 Printers have these extender hoses installed, and do not need this kit. Not all AGFA d-lab.2 Printers have these extender hoses installed from the factory. If your d-lab.2 does not have the extender hoses installed, then solutions falling from the top of the bleach-fix replenishment tank during a mixing cycle can introduce air and cause foaming. The installation of the extender hoses in the KODAK Upgrade Kit for AGFA d-lab.2, will eliminate the potential for foaming.

Instructions for Installation

TOOLS NEEDED: #2 Philips head screwdriver
Flat head screwdriver
Adjustable Pliers

PARTS in KIT: Extender tubes (2)
Plastic clamps (2)
Instructions

SAFETY: Use caution when working around chemicals. Wear eye protection and protective gloves made from Neoprene or nitrile rubber. For more information about potential health hazards and safe handling of specific KODAK Chemicals, see the chemical labels and the Material Safety Data Sheets (MSDSs) for the chemicals. MSDS copies are available at the Kodak website at www.Kodak.com/go/photochemicals.

PROCEDURE: Two extension tubes (Figure 1) will be installed in the bleach/fix replenisher tank. The bleach/fix replenisher tank is the middle of the three replenisher tanks. A checklist and detailed step-by-step instructions are given below. Be sure the tubes are positioned toward the outside of the tank so that they do not interfere with the float on the empty level sensor or the full level sensor (Figure 1).

If you have any questions, call the KODAK Information Center, Photofinishing Group at 1-866-352-4367.

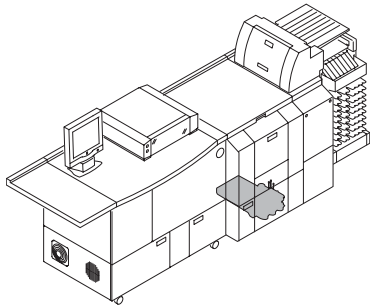

F005_0034BA

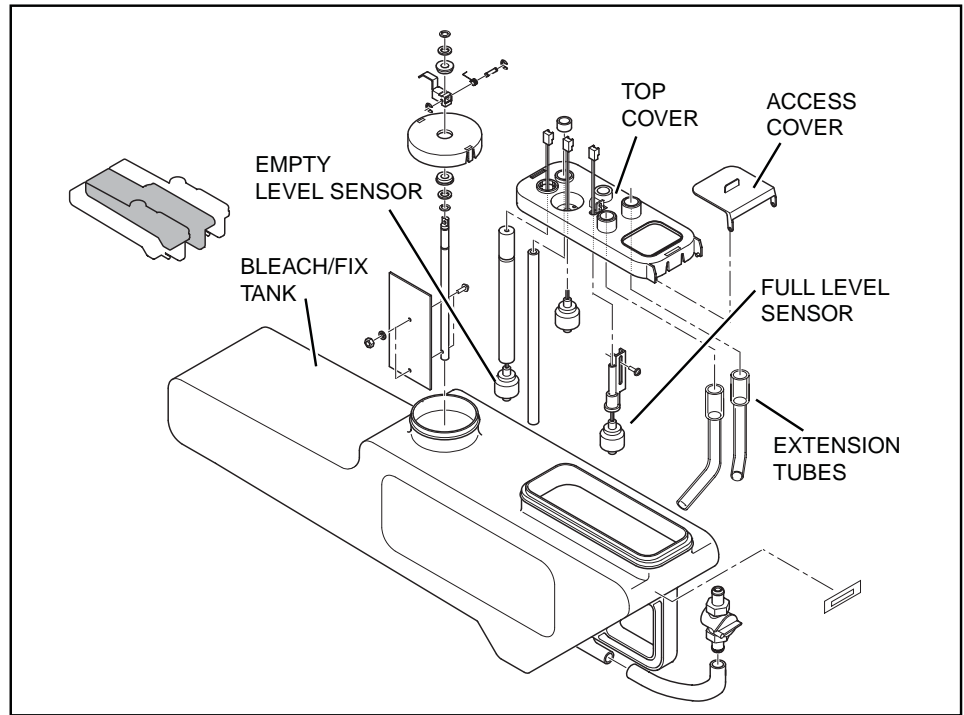

Figure 1: Image/schematic of bleach fix and bleach/fix replenisher tank

NOTES:

1. The installation procedure is best done when the replenisher tanks are low or empty. This will facilitate access to the tanks and allow a view of the float on the empty level sensor. One option is to drain part of the bleach/fix chemistry into a clean container and pour it back into the replenisher tank when the installation procedure is completed. Turn off the machine if draining chemistry. A full tank will hold 7.5 L of chemistry.
2. The tubes have one end wider than the other. The wide end attaches to the fittings on the bottom side of the top cover. Although not shown in Figure 1, there are also plastic clamps to secure the tubes.

CHECKLIST (Detailed step-by-step instructions follow the checklist.)

- Turn off power to machine.
- Remove front panel covering replenisher tanks (Fig. 2).
- Remove stainless steel plate holding replenisher tanks (Fig. 3).
- Disconnect two black delivery tubes from Bl/Fix replenisher tank (Fig. 4).
- Slide out tank approximately 4 cm and lift up front of top cover (Fig. 4).
- Install extension tubes, sliding as far onto fitting as possible (Fig. 5a and 5b).
- Check positioning so that tubes do not interfere with float (Fig. 5c).
- Attach and tighten clamps (Fig. 5b).
- Slide tank back into place and replace top cover.
- Open top access cover and ensure there is no interference with floats.
- Reconnect black delivery tubes to top cover.
- Replace stainless steel plate holding replenisher tanks.
- Replace front panel.
- Turn on power to machine.

Step-by-step procedure to install extension tubes:

Step 1: Turn off machine and turn off power.

This is for safety considerations as well as a practical issue.

IMPORTANT: If you do not turn off the machine, the empty level sensor will likely be activated as the lid is raised in step 5. This will cause the software to incorrectly call for a new replenisher mix when none is required.

Step 2: Remove the 2 screws holding the front panel over the replenishment tank and remove the front panel.

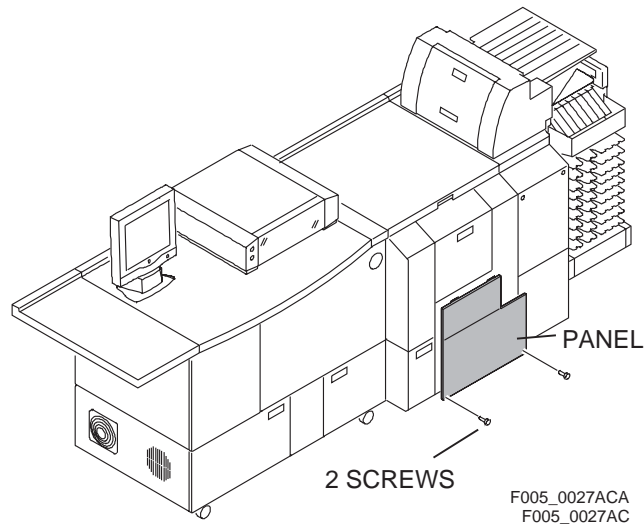

Figure 2

Step 3: Remove the stainless steel plate holding the replenisher tanks by removing two screws.

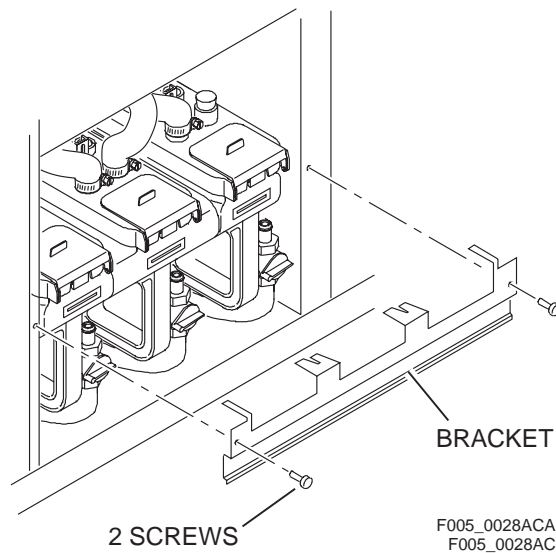
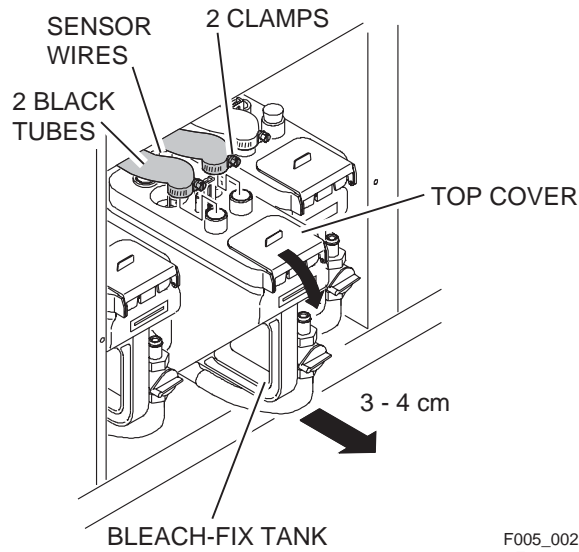

Figure 3

Step 4: Remove lower end of the two black delivery tubes from connections on the top cover.
 Loosen clamps on the two flexible black delivery tubes connecting to the top cover of the tank. Slide delivery tubes off of the connections to the top cover. Figure 4 below shows the location of the clamps.



F005_0029ACA
 F005_0029AC

Figure 4

Step 5: Carefully pull the middle bleach/fix replenisher tank out approximately 3 to 4 cm and tilt up the front of the cover to access the bottom. The front of the top cover clips to the tank. Pull out gently on the center section to lift the top cover.

CAUTION: The tank will not slide out completely. Sensor wires are connected to the top cover. Do not strain the wires.

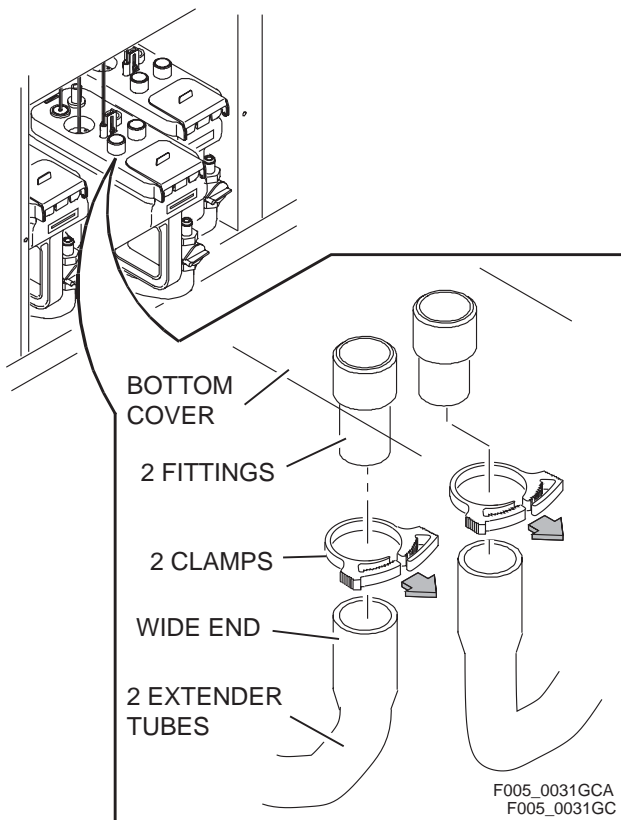

F005_0031GCA
 F005_0031GC

Figure 5a

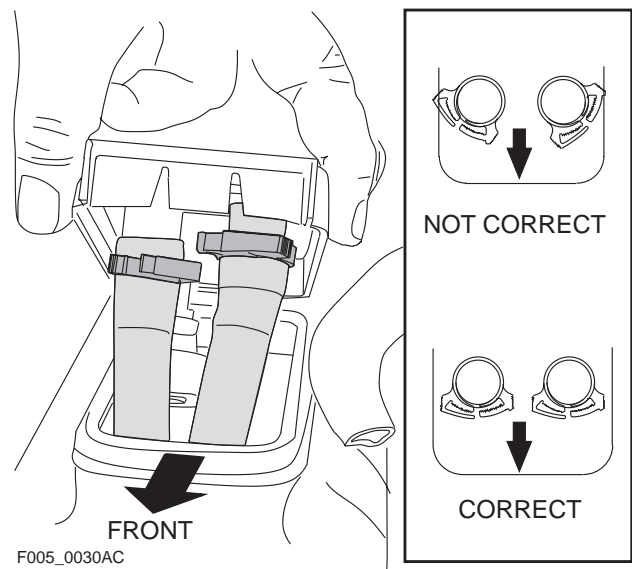

F005_0030AC

Figure 5b

Step 6: Install wide end of extender tubes onto two fittings on bottom of top cover.

Wetting the inside of the tubes will allow easier installation.

One end of each tube is expanded to fit onto the connectors. Push on as far as possible. There is also a clamp to secure each tube. See step 7 for a description of the clamp. Figure 5b shows the tubes installed.

WARNING: Position tubes so they do not interfere with the float on the empty level sensor. Angle the ends of the tubes towards the outside walls. See examples in Figure 5c that show the correct and incorrect positioning of the extension tubes.

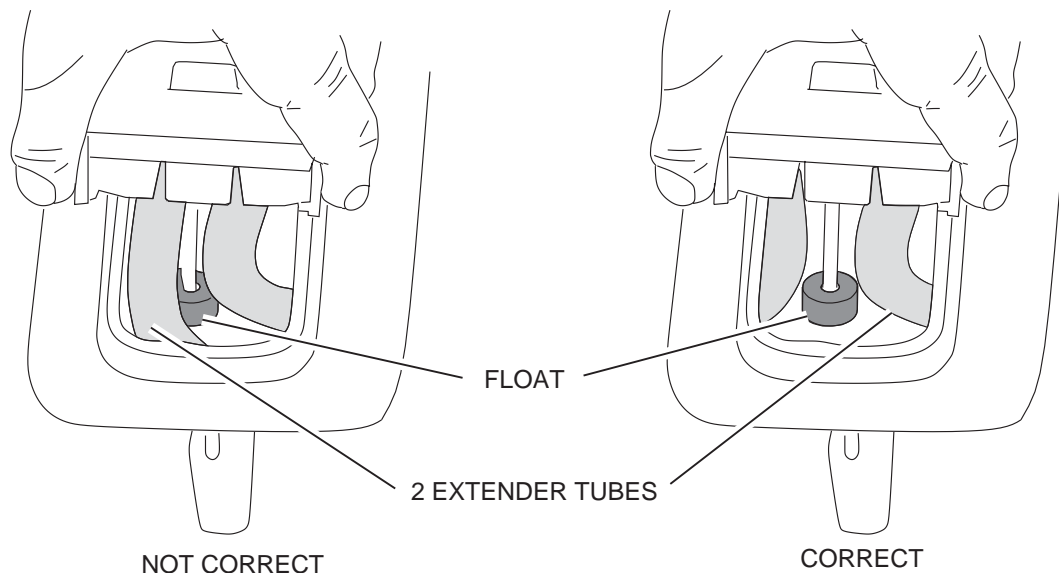

F005_0032BCA
F005_0032BC

Figure 5c

Step 7: Attach one clamp on each tube.

Tighten snugly with a pair of pliers. Do not over tighten.

The clamps will need to be offset (one higher, one lower) to fit.

WARNING: The closure of the clamp must be facing the front and center. They will interfere with closing the top cover if the clamp closure is on the side.

Step 8: Slide tank back into place and replace top cover.

Step 9: Open top access cover and make sure tubes do not interfere with float.

Step 10: Reconnect black delivery tubes removed in Step 4. Tighten clamps

Step 11: Replace stainless steel plate removed in Step 3.

Step 12: Replace front panel removed in Step 2.

Consumer Digital Imaging Group
EASTMAN KODAK COMPANY • ROCHESTER, NY 14650

Kodak

Using the KODAK EKTACOLOR
Processing Cartridge 92/110
KODAK Publication No. **CIS-280**

Kodak, Kodak Professional, Edge, Ektacolor,
Endura, Portra, Prime, Profoto, Pro Image,
Royal, Supra, and Ultra are trademarks.

New 02-07

Using KODAK EKTACOLOR Processing Cartridge 92/110

CAT No. 144 0775, for Professional Color Papers in KODAK PROFESSIONAL RP 30 and SRP 30 Laser Printers

The KODAK EKTACOLOR Processing Cartridge 92/110 is designed for use with the KODAK PROFESSIONAL RP 30 Laser Printer and the KODAK PROFESSIONAL SRP 30 Laser Printer.

The EKTACOLOR Processing Cartridge 92/110, CAT No. 144 0775, replaces KODAK EKTACOLOR Processing Cartridge 75, CAT No. 528 5887.

The drop-in cartridge of paper processing chemicals will process 92 square metres (990 square feet) of color papers, such as KODAK PROFESSIONAL PORTRA ENDURA, SUPRA ENDURA, ULTRA ENDURA, and ENDURA Metallic Papers. The cartridge will produce prints with rich, bright colors and excellent shadow detail. It provides production efficiency that will satisfy even the highest-volume lab operations.

Note: The KODAK EKTACOLOR Processing Cartridge 92/110 can also process 110 square metres (1184 square feet) of KODAK EKTACOLOR EDGE, ROYAL Digital, and KODAK PROFESSIONAL PRO IMAGE and PROFOTO Color Papers.* For information on using the 92/110 processing cartridge with these color papers, see Publication CIS-280, *Using the KODAK EKTACOLOR Processing Cartridge 92/110, CAT No. 144 0775, for Processing KODAK EKTACOLOR EDGE, ROYAL Digital, and KODAK PROFESSIONAL PRO IMAGE and PROFOTO Color Papers.*

EKTACOLOR Processing Cartridge 92/110 will be offered worldwide. It will be available in the U.S. and Europe in spring 2007, and worldwide during the summer 2007.

*Not available in all countries

CARTRIDGE DESCRIPTION

Each cartridge case holds two processing cartridges. Each cartridge contains concentrates to make 4.5 litres (1.2 gal) of developer replenisher, 7.5 litres (2 gal) of bleach-fix replenisher, and 4.5 litres (1.2 gal) of stabilizer replenisher to process 92 square metres (990 sq feet) of paper.

KODAK PROFESSIONAL RP 30 and SRP 30 Laser Printers will prepare the replenisher solutions directly in the replenisher storage tanks of the printer processor. The printers will automatically signal when a replacement cartridge is needed.

CONVERTING TO KODAK EKTACOLOR PROCESSING CARTRIDGE 92/110

To convert to the PC 92/110 cartridge follow these steps:

- 1) Before converting, make sure you use up all remaining inventory of KODAK EKTACOLOR Processing Cartridge 75, CAT No. 528 5887.
- 2) Change replenishment rate settings: When loading your first 92/110 processing cartridge, CAT No. 144 0775, make the following changes to the replenishment rates in the RP 30 or SRP 30 printer software. Follow the procedure listed below:

Rates for 92 m²: (for RP 30 and SRP 30)

To change replenishment rates:

- Touch: **Settings
Machine settings
PP Replenishm.**

The replenishment settings part of the screen should look as follows (note that new replenishment rates are shown):

Chemicals	Normal replenishm.	
	Chemicals [ml/m ²]	Water [ml/m ²]
DEV	49	11
BX	82	0
STB	49	151

To set new Paper Processor replenishment rates:

- Touch the first button next to **DEV** and enter **49**. (BX and STB will automatically change.)
- Touch the second button to the right of **DEV** (**DEV Water**) and enter **11**.
- Touch the second button to the right of **STB** (**STB Water**) and enter **151**.
- Touch **OK** to save the new values.

Caution: Do not press the Reset to default button.

Reset to
default



If you press the button, the replenishment settings will be set back to the PC-75 rates and over-replenishment will occur. You must then re-enter the above values.

PROCESSING STEPS AND CONDITIONS

The steps and conditions of the process cycle in the KODAK PROFESSIONAL RP 30 and SRP 30 Laser Printers follow.

Table 1 Processing Steps and Conditions

Solution/Step	Time* (sec)	Temperature	Replenishment Rate† mL/m ²
Developer	33	40.0 ± 0.3°C 104.0 ± 0.5°F	49 replenisher 11 water
Bleach-Fix	33	38 ± 3°C 100 ± 5°F	82
Stabilizer	69‡	37 ± 3°C 99 ± 5°F	49 replenisher 151 water
Dry		Not over 70°C (158°F)	—

*Immersion time plus crossover time to the next tank.

†The replenishment rates are starting-point recommendations.

‡Four stabilizer tanks plumbed for countercurrent flow.

Note: All solutions and tanks are automatically circulated and filtered.

Replenishment Rates

The rates in Table 1 are starting-point recommendations. Your replenishment rates will also depend on these factors:

- type of paper processed
- exposure level of the paper and resulting print density
- other variables of the processing system, such as production volume

If you change any one of the three replenishment rates in the Chemicals column, the other two will automatically be changed so that all replenisher chemistry will run out at the same time. We recommend that changes be made only to the developer rate. Changes can be made to any one of the three water rates without changing the other two.

Note: We do not recommend operating at replenishment rates lower than those given in Table 1.

Developer. If necessary, adjust the replenishment rate according to your control plots (see “Using Control Strips to Monitor the Process”).

Bleach-Fix. The bleach-fix replenishment rate assumes minimum carryover of developer. If developer carryover is greater than normal, problems such as retained silver may occur. If you detect retained silver, verify that the replenishment rate is set correctly and that the processor rollers are adjusted to minimize developer carryover. See the printer manual for specifications and adjustments for squeegee rollers.

Filtration

Processing solutions and wash water may contain some insoluble materials. If these materials aren't filtered out, they can stick to the paper, tank walls, rollers, and lines, and may damage the paper. Change the filters regularly as a part of routine maintenance.

Drying

The maximum drying temperature setting in the software of KODAK PROFESSIONAL RP 30 and SRP 30 Laser Printers is 70°C (158°F).

Low Utilization

The number of prints that you produce each week determines the utilization of the printer processor. If your utilization is low, oxidation and evaporation will affect the activity of the processing solutions and may increase the D-min of the paper.

During periods of low utilization, be sure to turn off the processor when it's not in use to avoid oxidation and evaporation. In extreme cases of low utilization, you may need to discard the chemicals in the processor and replace them with fresh tank solutions.

SAFE HANDLING OF PHOTOGRAPHIC CHEMICALS

Handle all chemicals carefully. When you mix solutions, wear goggles or a face shield, a protective rubber apron, and protective gloves made with neoprene or nitrile rubber. Clean protective clothing after use to remove any chemical residue that can cause contamination. For more information about potential health hazards and safe handling of specific KODAK Chemicals, see the label and the Material Safety Data Sheet (MSDS) for the chemical. Consult the MSDS for regional contact information. MSDS copies are available at www.Kodak.com/go/photochemicals.

PREPARING FRESH TANK SOLUTIONS

Follow these instructions to prepare developer, bleach-fix, and stabilizer working tank solutions for the KODAK PROFESSIONAL RP 30 and SRP 30 Laser Printers from the concentrate solutions in the KODAK EKTACOLOR Processing Cartridge 92/110.

Preliminary Steps

- Before removing bottles from the cartridge, identify the concentrate bottles needed by looking at the cartridge diagram on the front label of the 92/110 processing cartridge. Note the order of each different concentrate bottle, and what each is. Also note that the CD and BX-B have the same size bottle, but can be identified by the order in the box and by the fill volume noted in the diagram. The diagram on the label will appear as follows:

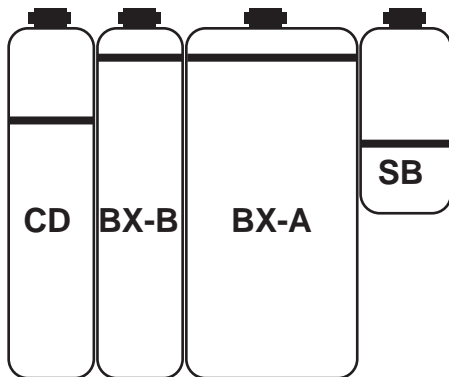

You will need two bottles of each part to prepare the working tank solutions.

- To prepare the developer tank solution, you will also need KODAK EKTACOLOR RA Developer Starter. CAT numbers vary by regions and are as follows:

Region	CAT No.
US&C, Latin America (Northern)	102 6681
Europe, Africa, Middle East	527 8957
Latin America (Southern)	632 0238
Greater Asia Region	444 5839 403 6596

- Assemble the following equipment for accurate measurement of the concentrates and water:
 - graduated cylinder that can measure volumes up to 1 litre
 - container to measure volumes of water up to 10 litres
- Remove the racks from the processor tanks and rinse the tanks with water. **Be sure to close the drain valves again before adding the fresh solutions to the tanks.**

Mixing the Tank Solutions

Mix the working tank solutions for the stabilizer, bleach-fix, and developer as follows:

Stabilizer. Identify the two stabilizer concentrate bottles from the two EKTACOLOR Processing Cartridge 92/110 cartons. To mix solution for the four stabilizer tanks, you will need to split the volume of concentrate in each bottle in half.

Use the stabilizer concentrate to mix the working tank solution for **each** tank as follows:

For Each Stabilizer Tank	Volume
Add water to each stabilizer tank	10.9 litres
Add one-half bottle of stabilizer concentrate (labeled SB on diagram)	Approximately 87 mL
Total volume per tank	11 litres

Bleach-Fix. Identify the bleach-fix Part A and Part B concentrate bottles from the two EKTACOLOR Processing Cartridge 92/110 cartons. **Be very careful to avoid contamination of the developer with bleach-fix.**

For Bleach-Fix Tank	Volume
Add water to bleach-fix tank	12.4 litres
Add contents of two bottles of bleach-fix concentrate, Part A (labeled BX-A on diagram)	Entire contents of two bottles
Add contents of two bottles of bleach-fix concentrate, Part B (labeled BX-B on diagram)	Entire contents of two bottles
Total tank volume	18.4 litres

Developer. Follow the procedure below to prepare the developer working tank solution. To ensure good performance, take special care in mixing the developer.

For Developer Tank	Volume
Add water to developer tank	15.7 litres
Slowly add contents of two bottles of developer concentrate (labeled CD on diagram)	Entire contents of two bottles
EKTACOLOR RA Developer Starter	1100 mL
Total tank volume	18.4 litres

Reinstalling the Racks and Bringing the Tank Solutions to Temperature

When you fill the tanks with the new mixes, they will appear only partially filled. When you reinstall the racks in the tanks, the racks will displace more solution volume to fill the tanks.

Install the racks by slowly lowering them into the tank. When you have reinstalled all the racks and have verified that all the tanks are filled with solution, turn on the recirculation and heater system and bring the solutions up to operating temperature:

Solution Tank	Temperature °C
Developer	40.0 ± 0.3
Bleach-Fix	38 ± 3
Stabilizer	37 ± 3

Note: After mixing, rinse the concentrate bottles and dispose of them in an approved manner. See “Managing Empty Cartridges.”

Maintaining Stabilizer Tank Solutions

All photographic processing equipment requires ongoing maintenance to ensure that wash tanks and stabilizer tanks remain clean and provide proper washing of photographic materials. This is true for traditional “plumbed” running-water wash systems as well as “non-plumbed” stabilizer wash systems commonly used in minilab processors. Without occasional tank and rack cleaning and replacement of the stabilizer, you may experience dirt and precipitate buildup in the tanks.

We recommend that you clean stabilizer tanks and racks and replace the stabilizer solution if you experience an increase in D-min—typically seen as yellow stain—or whenever you see excessive dirt on print surfaces.

The need for stabilizer tank maintenance will vary with factors such as water quality and the production volume of the processor. Most labs find that they need to change stabilizer at intervals ranging from once every few weeks to once every few months. Replacement of solution in the first tank or the first two tanks following the bleach-fix tank may be sufficient to resolve problems.

The following procedure for replacing the stabilizer tank solution recommends the use of KODAK EKTACOLOR PRIME Stabilizer and Replenisher LORR. When you use this stabilizer, you avoid having to use a portion of the chemicals in the KODAK EKTACOLOR Processing Cartridge 92/110.

Note: For all maintenance steps, observe the precautions given under “Safe Handling of Photographic Chemicals.”

To change the stabilizer:

1. Drain the existing tank solution and save it for silver recovery.
2. Remove the racks and clean them thoroughly with a soft sponge or brush under running water. Also brush any dirt or residue from the sides of the stabilizer tanks, and flush them with warm water.
3. To refill the tanks with fresh stabilizer, add 10.9 litres of water to each of the stabilizer tanks. If you are using stabilizer supplied in a dispenser bottle (European CAT 527 0863), then start with 10.8 litres of water.
4. To each tank, add the contents of one bottle of the 10-litre size of KODAK EKTACOLOR PRIME Stabilizer and Replenisher LORR. If you’re using a stabilizer unit that makes a larger volume of solution, measure 100 mL of the concentrate and add it to each tank.

If you are using dispenser bottle* CAT 527 0863, then add the quantity 2x the level A mark. The tank will appear partially filled.

*Not available in all countries
5. Slowly insert the stabilizer racks in each tank; the solution will mix and the tank will fill.

USING CONTROL STRIPS TO MONITOR THE PROCESS

You can use KODAK PROFESSIONAL Pro Strips Color Negative Paper Control Strips, Process RA-4 (box of 50, CAT No. 129 8587) to monitor and help maintain process performance. For instructions on processing control strips, see the user’s manual for the printer. For information on the use and diagnostic features of the control strips, see KODAK Publication No. Z-130, *Using KODAK EKTACOLOR Chemicals*, Section 8, “Process Monitoring and Troubleshooting with KODAK PROFESSIONAL Pro Strips.” Kodak publications are described and available from www.Kodak.com/go/photochemicals.

To calculate control-strip aim values for process monitoring with the EKTACOLOR Processing Cartridge 92/110 in the RP 30 or SRP 30 Laser Printer, you will need to apply process adjustment factors. Use the adjustment factors in addition to the correction factors that are supplied with the Pro Strips.

After reading the densities of the supplied reference strip on your densitometer, first apply the correction factors packaged with the reference strip. Then add the values from the following table. The corrected density values are the aim values for your batch of control strips. You will need to apply the adjustment factors each time you switch to a new batch of control strips.

Table 2 Process Adjustment Factors

Measurement	R	G	B
BP	+0.07	+0.04	+0.05
HD	+0.15	+0.15	+0.11
LD	+0.10	+0.10	+0.08
D-min	+0.01	0	0

SILVER RECOVERY

The overflows from the developer and bleach-fix tanks are collected in a common tank on the KODAK PROFESSIONAL RP 30 and SRP 30 Laser Printers. The stabilizer overflow is collected in a second tank. The two effluent tanks are connected at the top. If one is full, it will overflow into the other tank. Typically, silver concentrations in the developer/bleach-fix effluent tank will be 2 to 4 g/L of silver. The stabilizer effluent tank will have a typical silver concentration of 0.4 to 0.7 g/L.

You can effectively use common silver-recovery methods with the combined effluent from both effluent collection tanks. If your lab has other processors, you can combine the effluent from the RP 30 and SRP 30 Printers with the other effluent solutions and use your current silver-recovery methods.

Publications on silver management that include recommendations and descriptions of silver-recovery options are available in the Silver Management section of the Kodak Environmental Services Publications Center at www.Kodak.com/go/KES.

MANAGING EMPTY CARTRIDGES

In most regions, it should be possible to participate in a local community recycling program. Check with program authorities to determine if these packaging materials are eligible for local recycling. If they are accepted, disassemble the package and place the bottles and corrugated material in your recycling bin. Follow all material preparation instructions from the recycler.

See KODAK Publication No. CIS-148, *Recycling KODAK Photochemical Containers*, for more information on preparing the empty bottles for recycling. CIS-148 and other publications on waste management are available from www.Kodak.com/go/KES.

If local recycling is not an option, dispose of the empty bottles and the package with your normal solid waste.

MSDS INFORMATION

Kodak will provide Material Safety Data Sheets (MSDSs) with the first delivery of the cartridges. MSDSs are also available from www.Kodak.com/go/photochemicals.

In the United States, OSHA Warning Labels for printer processor tanks are available at www.Kodak.com/go/KES. These warning labels for chemical working tank solutions can assist you in complying with the OSHA Hazard Communication Standard. When combined with the use of Material Safety Data Sheets, they'll help ensure that users are informed about chemicals in the workplace.

Consumer Digital Imaging Group
EASTMAN KODAK COMPANY • ROCHESTER, NY 14650

Kodak

Using the KODAK EKTACOLOR
Processing Cartridge 92/110
KODAK Publication No. **CIS-239**

Kodak, Kodak Professional, Edge, Ektacolor, Endura,
Portra, Prime, Pro Image, Profoto,
Royal, Supra, and Ultra are trademarks.

Major Revision 02-07